

UNIPHOS 501DT - KwikSense Pro Digital Transmitter

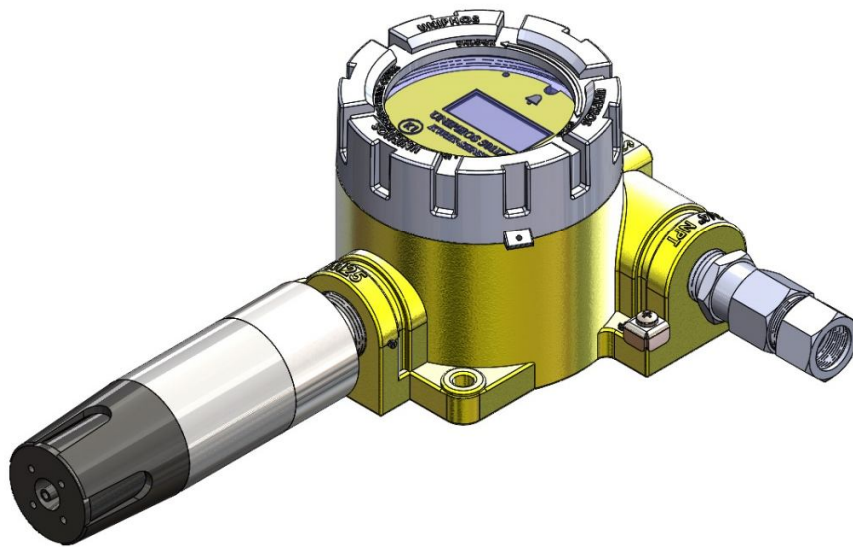

INSTRUCTION MANUAL



UNIPHOS

Uniphos Envirotronic Pvt. Ltd.
Readymoney Terrace,
167, Dr. Annie Besant Road,
Worli, Mumbai - 400 018.
India
Tel: +91 22 6123 3500

INDEX

	PG NO.
A. Introduction:	4
B. Installation:	6
Overview	6
Selecting Location	7
Mounting guideline	8
Installation	10
4-20mA Loop installation	12
Relay Cable guideline	12
Power Supply & Signal (4-20mA)	13
Settings	15
C. Operation:	17
Gas alarm Conditions & Advice	18
Fault alarm Conditions & Advice	19
D. Calibration:	20
Guidelines	20
Calibration procedure	20
Calibration Diagnostics Protection	22
Important Notes	23
E. Other Settings:	23
F. Maintenance:	24
Cleaning a Sensor	
Clearing a Sensor	
Caution Notes	
G. Trouble shooting guide:	25
H. Specifications:	26
I. List of gases available:	28
J. Modbus Register Map:	30

**Warning**

Inappropriate use, maintenance or servicing may affect the function of the device and thereby seriously compromise the user's life.

Before use the product operability must be verified. The product must not be used, if the function test is unsuccessful, it is damaged, a competent servicing/maintenance has not been made, genuine UNIPHOS spare parts have not been used.

Remove and reinstall sensors carefully, ensuring that the components are not damaged; otherwise the approval may be adversely affected, wrong readings could occur, and persons relying on this product for their safety could sustain serious personal injury or death.

Attention!

The device must be installed only in compliance with the applicable regulations, otherwise the safe operation of the instrument is not guaranteed.

Test gas concentration has to be checked and device has to be calibrated, if the range is changed.

After completion of lifecycle of this instrument, dispose it in accordance with federal, State, and local environmental control regulations.

A. Introduction:

The UNIPHOS range of gas transmitters provide comprehensive monitoring of flammable, toxic & Oxygen gas hazards in potentially explosive atmosphere, both indoor & outdoor.

"UNIPHOS 501DT - KwikSense Pro" gas transmitter provides continuous monitoring of the atmosphere for hazardous gases in the workplace and is virtually maintenance-free. Its revolutionary design utilizes advanced microcontrollers and allows for enhanced diagnostics and fault analysis. Advanced design features make installation and operation simpler than ever, saving you time & money. Transmitter is built as common platform with provision to plug in smart & swappable sensor module of users choice. Smart & swappable sensor modules are available for variety of flammable gases, toxic gases & Oxygen. Plug in sensor replacement is extremely easy operation.

The transmitter provides 4-20mA output signal which can be connected to any control system like DCS, PLC etc. Designed with non-volatile memory, the transmitters have total memory retention capacity. There is provision to have auto-inhibit of the internal relay contacts during the maintenance.

Users can modify transmitter operation using the LCD & magnet switches without ever needing to open the unit. Magnetically coupled non-intrusive calibration can be easily performed by one person with ease. Normally, only a periodic calibration check is needed to assure dependable performance. Continuous backlight provision is given on the LCD screen.

The LCD/OLED is an intuitive user interfaces, indicating the following:

- Model name & Sr. No.
- Gas name being monitored and concentration level in ppm, %LEL or % V/V unit etc.
- Alarm levels (which are user settable viz. Low, High or Fault).
- Date of last calibration.
- Prompt to apply the zero gas & span gas during the calibration mode.

- Indication if a toxic or combustible gas sensor has "failed" in the self-test or sensor absent.

Modular design of this product helps user to have ease in installation, operations & maintenance throughout the product life. It has integral mounting plate consisting of four holes on the transmitter body for easy mounting. The transmitter may be fixed directly to a surface on the walls or similar support structure.

On activation of the power supply to the transmitter; within few seconds it recognizes the sensor plugged into it, tests it and configures itself to the sensor plugged in.

All the transmitters are supplied pre-configured & include two programmable alarm relays & one fault relay. The scale, range, relay operation, alarm set points can be adjusted using the transmitter's LCD/OLED and non-intrusive magnetic switches. Outputs are automatically inhibited during adjustments there by reducing the risk of false alarm at the control panel during maintenance.

The transmitter unit ensures easy installation and the fastest routine operation by removing the need for hot work permits in hazardous areas. Using easy to replace the pre-calibrated plug-in sensor modules, downtime is also reduced and on-going costs are minimized.

The sensors have proven history of reliable, long term performance and are relatively unaffected by ambient temperature & humidity variations. Gas enters the transmitter's sensor by convection and diffusion through a sintered stainless steel or wire mesh screen at the opening of the sensor housing. The transmitter is capable of responding to a momentary puff of gas that would otherwise remain undetected.

The transmitter's explosion proof design allows operation in areas where the combustible gas concentration may exceed the lower explosion limit (LEL). Its rugged construction ensures a long life span in almost any environment.

The transmitter incorporates the best of both proven and new technologies that offer versatility in addition to reliable safety mechanism. It is most cost effective product for new and retrofit applications.

B. Installation

Various parts of the gas transmitter are shown in the following diagram.

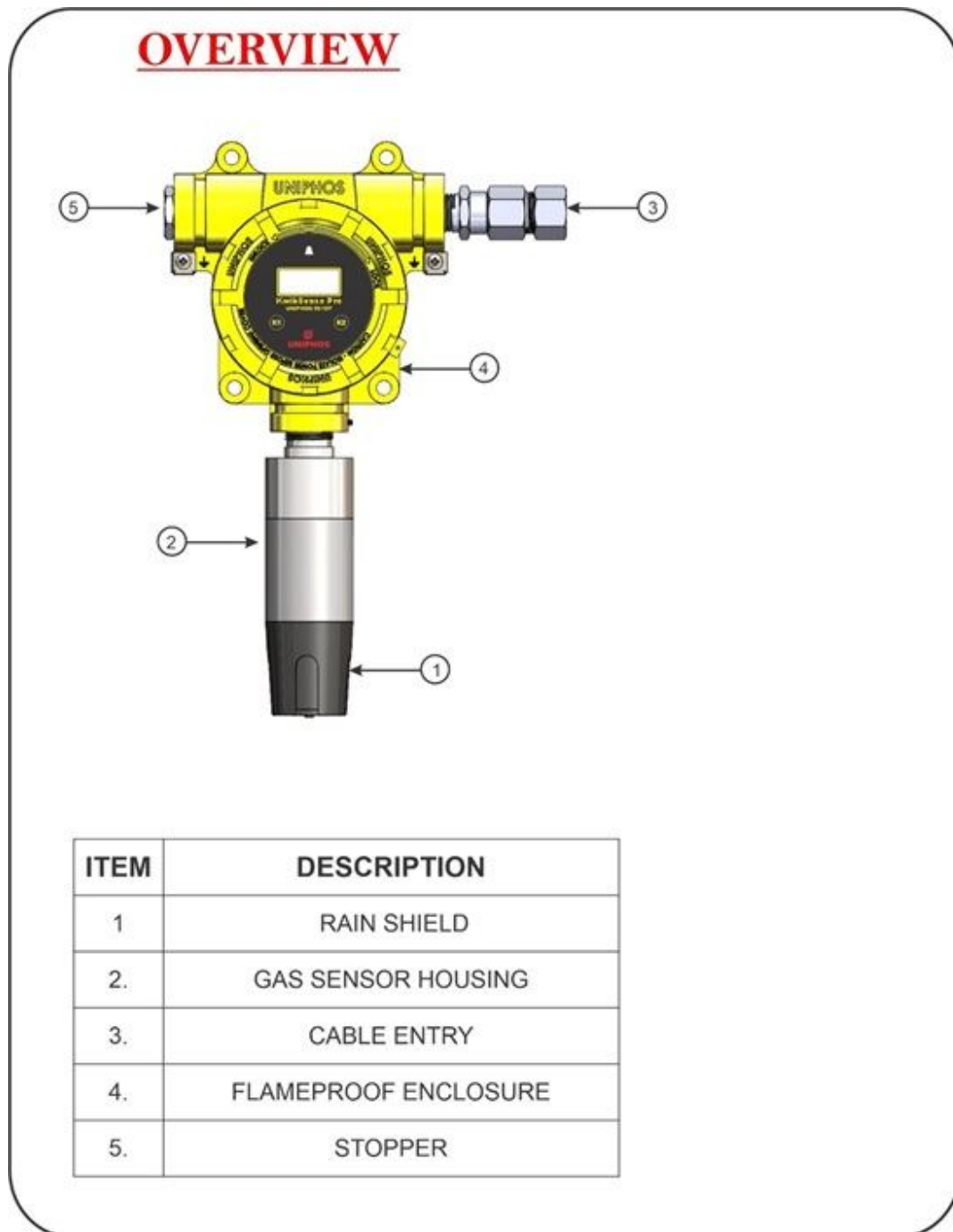

Figure 1. UNIPHOS 501DT - KwikSense Pro Transmitter overview

Selecting Transmitter Location:

Select the most suitable locations for each transmitter. Several factors should be considered when selecting location to install the gas transmitter. The following general suggestions should be considered.

- Air current: if there are fans, wind or other sources of air movement, gases may tend to rise or collect in certain areas of a facility. The local air currents should be assessed to aid in selecting the sensor locations. Outdoor situation considerations, such as prevailing winds, should be accounted for. Air convection can often be more important in determining gas concentrated areas than factors of vapor density.
- Vapor Density: When there are no air currents in the area, for gases lighter than air we suggest placing the sensor approximately 12" (30 cm) above the level of a potential leak source or near the roof in indoor installation. For gases heavier than air, we suggest placing the sensor 12" (30 cm) below the level of a potential leak source or near the floor or ground. Gases with density equal to air or slightly greater than air tend to rise particularly when the air currents are present.
- Gas emission source: as a rule, at least one sensor should be located in close proximity to each point where leak is likely to occur. This is particularly important when a liquid with low volatility is being monitored.
- Environmental factors: Consider the following in selecting the location
 - (i) Install sensors where they are protected from wind, dust, snow, water, vibrations and shock.
 - (ii) Observe the temperature & pressure variation surrounding the desired location. It should be within the specified operating temperature & pressure of the gas transmitter.

Mounting Guideline:

Modular design of the product simplifies the installation procedure. The Transmitter unit has two electronic circuit boards Viz. main processor board & relay board. Power supply & signal (4 -20 mA) connector is located on the bottom Relay board. NO-C-NC contacts of all the three Relays are provided on the green connectors located on the one side of the bottom Relay board. LCD display is plugged on the top board & secured with screws. Certified Explosion proof (Exd) enclosure of the unit is having provision for 3 openings for cable entries & connections. They are to be used as following (Refer fig.2)

- Opening on the Right hand side is equipped with 1/2" NPT/ M20 conduit fitting outlet. Use certified cable gland for cable entry. This entry is to be used for the power supply & signal cable connections.
- Opening on the Left hand side is equipped with 1/2" NPT/ M20 conduit fitting outlet. Use certified cable gland for cable entry. It is to be used for the Relay cable entries.
- One opening on bottom side is occupied by the smart sensor housing (sensor adaptor).
- If any one of the cable entries is not used, make sure to close it by using certified stopper.

The transmitter may be disassembled by removing the Top Processor board in order to get easy access to the bottom Relay board, simplifying the installation and field wiring.

Caution: Qualified personnel should perform the installation according to applicable electrical codes, regulations and safety standards. Ensure correct cabling and sealing, fitting practices are implemented.

Install the transmitter on the predrilled mounting flange. It is preferable to attach the transmitter to a wall or bracket, using bolts through diagonal mounting holes, and ensure mounting is done properly and there is no loose fitment.

Installation:

Transmission Range: The distance that the 4-20 mA signal can travel is dependent on several factors including the cable gauge. Maximum cable resistance allowed is 600 ohm less the controller resistance.

Assume a constant 24 VDC power supply (at 20 Deg C), copper wire and a controller resistance of 250 ohm. The signal range from the controller to the transmitter takes into account the return loop.

Note: The Uniphos-500 Series Controllers have a resistance of 250 ohm maximum.

Maximum cable lengths between the controller & transmitter:
The table give below is for guidance only. Users should calculate maximum distances using actual data for the cable being used.

Typical calculations assume minimum guaranteed controller supply of 24 VDC, minimum detector voltage of 18 VDC & maximum power supply under full alarm.

Table: 01

Typical cable data		Maximum cable length		
Cable size (Cross section)	Cable Resistance	Catalytic	EC	IR
	Ω/km	Meters	meters	meters
0.5 mm ² (20AWG)	36.8	356	478	420
1.0 mm ² (17AWG)	19.5	671	902	793
1.5 mm ² (16AWG)	12.7	1031	1384	1217
2.0 mm ² (14AWG)	10.1	1296	1741	1531
2.5 mm ² (13AWG)	8	1636	2197	1932

NOTE: Recommended cable size is 1.5mm²

Wiring Schematic diagram:

UNIPHOS transmitter can be wired in current source mode as shown in the below wiring schematic diagram.

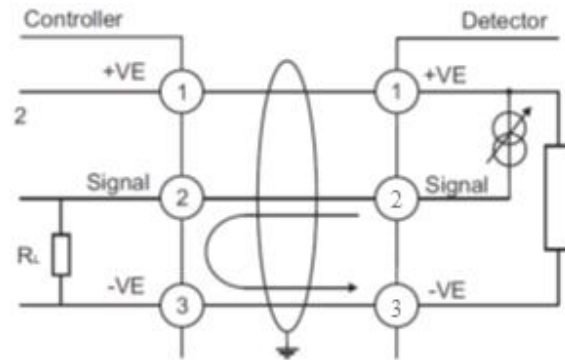

Figure 3

4-20mA Loop Installation:

Cable Routing: Separate cables are required for each Transmitter. In classified areas, the cable should be in conduit or it should be an Approved hazardous location cable

Power Supply: Ensure power supply meets the minimum Requirements of all components of the System. It is recommended to have a stable, clean, regulated power supply.

Caution: Polarity must be observed. If the return & +24 Volt wires are reversed, the transmitter will not work and may get damaged if energized. Do not apply electrical power to the transmitter until all connections are made, the sensor is in place and the transmitter is completely closed.

Steps to follow: (Ref Figure-4)

Relay Cable Guideline: (Optional feature)

The transmitter is equipped with potential free Relay contacts Viz. Low alarm, high alarm & Fault alarm. Connect the field device to the desired "Relay" as required by the application.

Relay connections are labeled: NO (normally open), NC (normally closed) & C (common). Attach wires as required on the field. For wire connections, please follow the steps given below.

- a. Remove the transmitter glass window cover & Top processor Board. Top processor board is to be removed carefully & patiently as shown in the demo video.
- b. On left hand side of the Bottom board one can see three green colored connectors viz. RLY1, RLY2 & RLY3.
- c. Relay Cable Installation: Attach the conduit, if applicable, pull cable into the enclosure through the cable gland on the left hand side of the enclosure as shown in the diagram. As per the requirements you may take out three wires viz. NO, NC & C for each Relay.

Power Supply & Signal (4-20mA) cable connections are indicated on bottom PCB.

After removing the transmitter glass window cover and Top Processor board, go for the power supply & 4-20mA signal wire connections as given below.

Locate 6 pin Green connector CN7 on the bottom board. Pull cable into the enclosure through the cable gland on the right hand side of the enclosure as shown in the figure 4.

Connect 3 wires as following:

Positive Supply (+24V) : +24 VDC to the labeled terminal.

Signal (4-20mA): 4-20mA loop signal to the labeled terminal

Negative Supply (GND) : Ground wire to the labeled terminal

Note: To avoid radio frequency interference (RFI), the shield (including Mylar) must be grounded. Simply tying a bare drain wire to ground does not ground a shield. Keep a shield as short as possible, tie the shield to the external grounding screw.

Figure 4. System wiring diagram

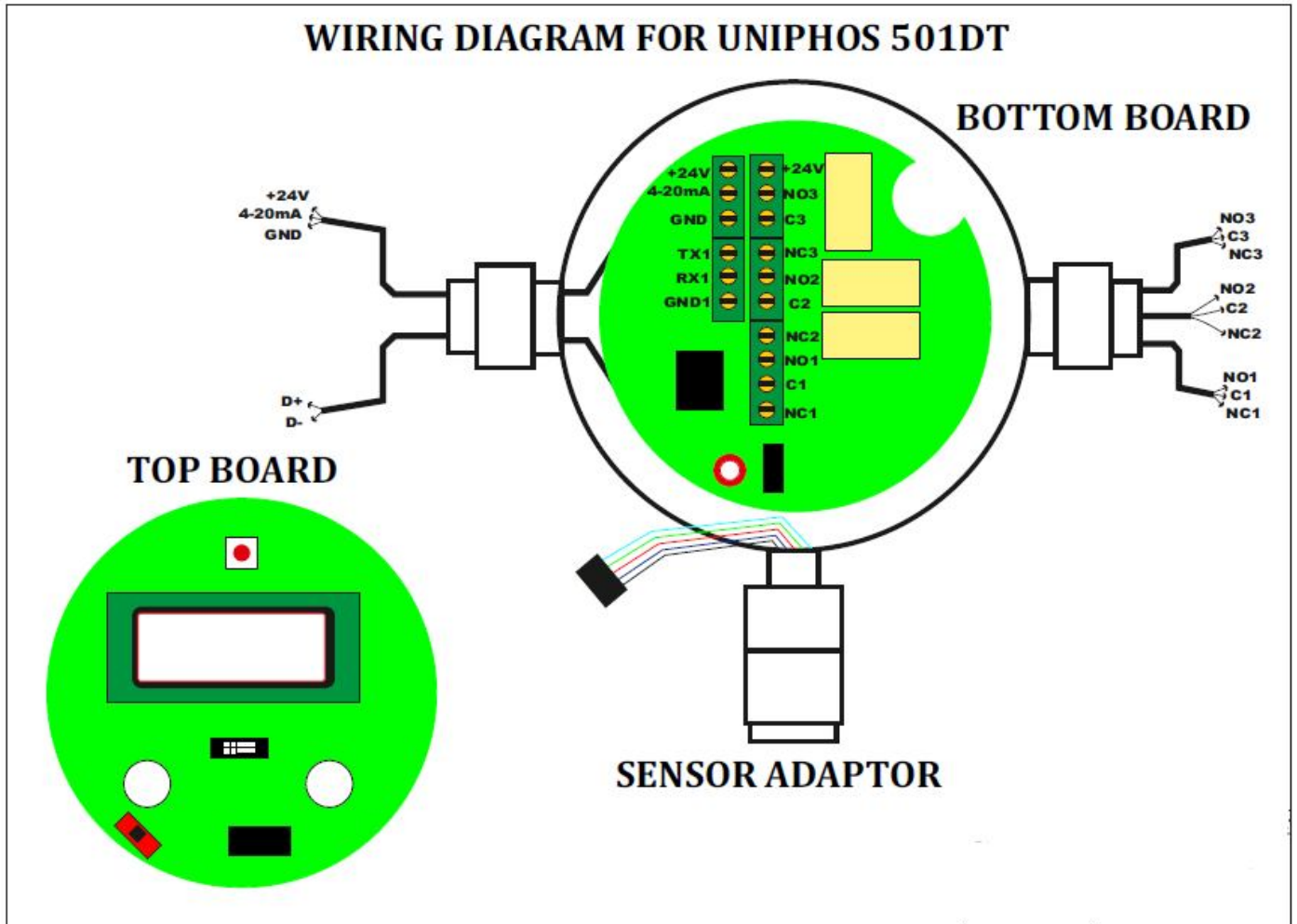

Settings:

The transmitter is calibrated & tested before shipping. Commonly used parameter values are set at the factory.

Provision is made for the following settings on site

- **Mute** - Yes/No
This provision is given to mute the hooter. During the calibration mode or during the routine test of the transmitter one can select "Mute" option to mute the hooter i.e. to disable the Relay activation.
- **Alm1** - (threshold Level Value)
This is Low alarm activation level.
- **Alm2** - (Short-term Threshold Level Value)
This is High alarm activation level.
- **Transmitter ID** -
Every transmitter has got unique ID code. The same is to be used when the transmitter is connected in the RS-485 MODBUS (RTU) data communication network. User can change this ID code on site as and when required.
- **Mask** -
This is factory setting. Please do not change it without consulting with the factory.
- **Relays/LED Test**
This provision is given to test the Relays & alarm LED operations site, when required.

To go into the parameter setting mode at any time, follow these steps.

- Touch the magnetic wand on the glass window at the key "K2"
- The transmitter display prompts for the "Password".
(Setting Password = 002)
- Follow the below prompt for parameter setting.

Table: 03 Prompts on LCD in Setting mode

Sr. No.	LCD prompts	Comment
1	Mute xxx	To enable / disable the relay output. xxx can be YES or NO . Key K1 is used to change it and K2 is used to confirm the change and go to the next prompt.
2	Alm1 (TLV) = Xxxx	To set the TLV (Threshold Limit Value) of the target gas, that is stored in the sensor. Key K2 is used to increment the digit where the cursor is positioned and key K1 is used to shift the cursor to the next (towards left) position. After the last digit, blinking cursor disappears, press K2 to accept changes and go to the next prompt.
3	Alm2 (STLV) = xxxx	In a similar fashion the set STLV (Short term Threshold value) and move to the next prompt.
4	Tx Id= xx	As explained for tlv & stlv setting, set the device Id (i.e MODBUS slave ID) Note: while using multiple Uniphos-501DT on Rs-485 line, each device id should be unique.
5	Mask = xx	Factory set
6	Testing LED-RLYs	To check (activate-deactivate) the LEDs and Relays. During this prompt, if key K1 is pressed, it activates all the LEDs and corresponding relays one by one. After that if key K2 is pressed, it comes-out from the setting mode.

Note: if the alarm condition exists, the transmitter does not allow the user to reset a latched Low or High alarm relay.

Operation

The transmitter provides continuous monitoring for the target gas. In the event of power failure, the transmitter will automatically reset itself back into the system loop after power is restored. The Smart Gas Sensor has non-volatile memory and is not be affected by power disruptions. All programmed information is protected with total memory retention.

At the time of power ON, the transmitter unit initializes and goes into the warm up. Following prompts are displayed on the LCD panel.

Table: 01 Prompts on LCD during Initialization

Sr. No.	LCD prompts	Interpretation
1	UNIPHOS 501(DT)	Model number of the product
2	DIGITAL X'MITTER	Name of the product
3	VERSION XXXX.XX	Current software version.
4	ERROR-NO SENSOR	Error message if sensor is not connected.
5	CAL DATE dd/mm/yy	Calibration date stored in the sensor, when it was last time calibrated (e.g. - 28/03/16)
6	SS LIFE XXXX	Sensor Life indicator (no of days).
7	AMBIENT XX.X	Temperature Indication.
8	XXXXXX YYYY	Name of the target gas stored in the sensor (e.g. O ₂) and gas concentration reading of the target gas sensed by the sensor (e.g. - 20.9)

Display: The LCD/OLED displays the present target gas concentration readings in ppm or % range. Backlight is always ON.

Note: It is recommended to calibrate the transmitter before first time use.

Output:

The 4-20mA loop current is sent in normal conditions (from 4 to 20mA according to the calibrated values & target gas concentration present on the site)

Gas Alarm conditions & Advice:

If the current gas concentration reading meets or exceeds either alarm set points, the transmitter alarm function activates.

When the alarm condition no longer exists, the transmitter exits alarm mode and enters normal mode operation.

The Oxygen Low and/or High gas alarm set points are user settable for either enrichment and/or deficiency alarm as desired.

Table: 04 **Alarms**

Alarm condition	Alarm Relay	Alarm LED (Visual Indicator)	LCD display
<p>LOW GAS ALARM The gas concentration meets or exceeds the low alarm set point</p>	<p>If relay is not muted, Low alarm relay triggers the connected device.</p>	<p>Visual Indicator (LED) turns to blue color</p>	<p>Numeric LCD display indicates the gas concentration currently present in ppm, % LEL or % V/V.</p>
<p>HIGH GAS ALARM The gas concentration meets or exceeds the high alarm set point</p>	<p>If relay is not muted, High alarm relay triggers the connected device.</p>	<p>Visual Indicator (LED) turns to RED color</p>	<p>Numeric LCD display indicates the gas concentration currently present in ppm, % LEL or % V/V.</p>
<p>OVER RANGE GAS ALARM The gas concentration meets or exceeds the measuring range</p>	<p>If relay is not muted, High alarm relay remains in activated position</p>	<p>Visual Indicator (LED) turns to Red color</p>	<p>Numeric LCD display indicates "OVR"</p>

Fault Alarm conditions & Advice:

In the event of a fault alarm condition, the fault alarm triggers activating the connected field device. The transmitter indicates the type of fault condition occurred.

Under the fault alarm condition, the fault alarm is activated.

Table: 05 **Fault conditions**

Fault condition	4-20mA Output	LED (Visual Indicator)	LCD display
Sensor self test fail: At start-up sensor self test failed	2 mA	Visual Indicator (LED) turns to red color	Numeric LCD display indicates the prompt "Error- No sensor "
Sensor Fault	2 mA	Visual Indicator (LED) turns to red color	Numeric LCD display indicates the prompt "Sensor -Fail "
Sensor Drift	2 mA	Visual Indicator (LED) turns to Red color	Numeric LCD display indicates the prompt "Sensor - Drift"

Calibration:

Guidelines:

- Calibration accuracy is never better than the calibration gas accuracy. We recommend a premium grade calibration gas. Do not use gas cylinder beyond its expiration date.
- Calibrate new sensor before use.
- Allow the sensor to stabilize before starting the calibration process (approximately 1 Hour).
- Calibrate the transmitters on regular schedule. (Recommended once in 90 days), in case of exposure to poisons & contaminants, frequency may be increased.
- Calibrate the transmitter if the ambient gas display value varies at start-up.
- It is recommended to calibrate the sensor, before changing the alarm set points.
- Calibrate (Zero) only in clean atmosphere, which is free from the target gas.
- Higher flow rate of calibration gas could give incorrect reading due to pressure build up over the sensor.

Calibration procedure

To go into the calibration mode at any time, follow these steps.

- Touch the magnetic wand on the glass window at key "K2 "
- The transmitter display prompts for the "PIN".
(Calibration Password = 001)
- Follow the below prompt for calibration

Table: 02 Prompts on LCD/OLED in Calibration mode

Sr. No.	Display prompts	Comment
1	PIN = 001	When magnetic wand is touched on key K2, LCD shows this prompt. On this prompt, by using keys K1 and K2, password can be entered. K2 is used to increment the digit highlighted by blinking cursor. Key K1 is used to Shift the cursor towards left. Once the digit (where the cursor is positioned) is changed, press K1 to shift the cursor to the next position. When none of the digit is blinking, key K2 is used to execute the password.
2	CALIBRAT MODE	After entering the correct password (001), LCD shows this prompt. It means now it is in

		calibration mode. Use K2 to proceed forward.
3	APPLY ZERO- Gas	The unit enters in "Zero-Cal" & display prompts to apply Zero-Gas or clean air free from the target gas. LCD indicates 30 second down count, this is the fixed time allotted for base line or zero cal setting. After successful base line setting, the LCD will give "Zero-Cal Done" prompt. In case if the base line of the sensor is not proper the Zero- Cal will fail & unit will show "Zero-Cal fail"
4	ENTER SPAN GAS VALUE = XXX	After "Zero cal Done" use K2 to enter in "Span-Cal" & prompt will appear for the Span gas (or calibration gas) value to enter (which is available for the calibration of the unit). On this prompt, by using key K2, span gas value can be incremented / decremented. Key K1 is used to toggle between increment/decrement mode, this is indicated by blinking cursor at the locations. If correct span gas value is entered on pressing K1 further, the blinking cursor disappears. Press K2 to accept the entered value and proceed further and select span time.
5	APPLY SPAN- Gas	After entering the span gas value and time, the unit prompts for applying the span gas. LCD/OLED also shows the down count. After successful span setting, LCD gives "Span-Cal Done" prompt. In case if the span setting of the sensor is not proper the Span- Cal fails & unit will show "Span-Cal failed". If span cal fails then the previous calibration data of the sensor will be restored back and fresh attempt of the sensor calibration need to be done. On successful calibration, the calibration date automatically gets updated.
6	AMB XX.X	Ambient Temperature indication screen. Use K1 & K2 to adjust the temperature (if required to calibrate). After updating the value acknowledge the change by K2.

Calibration Diagnostics Protection:

If calibration is incomplete, the transmitter automatically returns to normal operation and all previous calibration data is retained. Common cause for the transmitter to refuse calibration or for an incomplete calibration includes the following.

Background interfering gas is present. <i>If interfering gas is present during zero, the transmitter refuses to auto zero and exits the calibration routine.</i>	Combustible & toxic gas sensors: Wait for the transmitter to return to normal operation. Then apply pure air (Zero gas) and repeat calibration process.
Calibration gas cylinder runs empty during the calibration	Wait for the transmitter to return to normal operation. Replace the empty gas cylinder with a full cylinder & repeat process.
Calibration gas concentration is too low or too high. <i>Calibration gas concentration is not within expected range - either the concentration of applied gas (in ppm, % LEL or % V/V.) is too high or too low. The transmitter refuses to set span if the calibration gas is not within the expected range and exits the calibration routine.</i>	Change the value equal to the calibration gas concentration being applied & repeat the process.
Gas applied at wrong time. <i>Gas is applied before requested to do, or if gas is applied during zero, the transmitter refuses to proceed & exits calibration routine. The prior auto zero will be retained.</i>	Restart the calibration routine and apply gas, only when the LCD/OLED display prompts for it.

Important Notes:

The transmitter is required to be calibrated before initial use and at regular defined intervals thereafter. In addition, the calibration procedure should be performed, if any of the conditions occur.

1. The sensor has been replaced.
2. The transmitter has been exposed to gas concentrations at 100% of full scale for more than 5 minutes.
3. There has been a significant change in ambient conditions.
4. The transmitter is left unused over a period of 1 to 2 months or a long interval.

Other Settings:

Take the magnetic wand to K2, system will prompt to enter Password. Enter "004" and proceed forward for loop current settings (4-20mA). Please see the below table for more details:

Sr. No.	LCD prompts	Comment
1	4-20 out Enable/Disable	Used to enable/disable signal (4-20mA). Use K1 to toggle between Enable/Disable and K2 to accept changes and move forward.
2	Zero xxx	Used to adjust zero calibration for 4-20 mA signal. Adjust the three digit number by K1/K2 so as to have a 4mA signal output.
3	Span xxx	Used to adjust span calibration for 4-20 mA signals. Adjust the three digit number by K1/K2 so as to have a 20 mA signal output.

Maintenance:

The transmitter requires little maintenance. Occasionally the casing can be wiped with dry cloth. Other maintenance required is bump test, once in a month.

To keep the transmitter in good operating condition, perform the following basic maintenance as required.

- Calibrate, test & inspect the transmitter at regular intervals and after exposure to high concentrations.
- Keep an operations log of all maintenance, calibration & alarm events.
- Clean the exterior with a soft, damp cloth. Do not use solvents, soap or polishes.
- Do not immerse the transmitter in liquids.

Cleaning the Sensor:

The Smart sensor is secured in SS adaptor with sinter or filter screen (depending on gas). Clean the sinter/filter only with a dry brush, if required.

Clearing the Sensor:

The sensor has a high degree of resistance to common vapors & gases. The sensor most likely clears itself after exposing the sensor to the clean air and wait 10 to 30 minutes. Do not expose a sensor to the fumes of inorganic solvents (such as paint fumes) or organic solvents.

Caution Notes:

- It is recommended that the calibration gas concentration be 50% of the selected measurement range.
- For Oxygen, use pure air calibration gas.
- **NEVER** allow the unit to be used in direct sunlight & rain.
- **NEVER** expose the sensor to gas concentration higher than its prescribed range.

Trouble shooting guide:

Normal fault	Cause	Remedy
Transmitter unit not getting powered on	Loose connection on supply cables or Reverse polarity	Verify the cable connections on Connector CN7 of the bottom board.
Transmitter LCD/OLED showing Error- No sensor	Smart sensor is not properly plugged in the sensor housing	Remove the sensor & re-plug it again carefully
Transmitter LCD/OLED showing Error- Sensor -drift Or Over-Range	Sensor due for calibration	Go for calibration
Transmitter is initialized properly but loop current 4- 20 mA signal is not available.	Signal out wire (Green) shorted with the ground wire.	Cross verify the wiring. Check "4mA Enable/Disable" option

Specification:

Transmitter Type : 3-wire, 4-20 mA gas transmitter with
Advance microcontroller based circuitry.

Operating Voltage : 18 to 30 Volts DC (typically 24 V DC)

Output Current : Normal operation - Linear 4-20mA output
Calibration mode - Steady 3mA (automatic
Reset to normal Operation)
Fault mode - 2mA or less

Current Consumption : @ Toxic version & Oxygen - 80mA (max) at 24 VDC
@ combustible version - 120mA (max) at 24 VDC
@ IR version - 100mA (max) at 24 VDC
@ PID - 70mA (max) at 24 VDC

Sensor : Plug-in & swappable Smart Sensor for toxic &
Flammable gases, as per the Customer's
requirement. (Refer Video for proper sensor
swapping)

Memory : Non volatile memory inbuilt in the "Smart sensor
module", a Battery back-up is not necessary to
retain values in the event of Power outages.

Loop Resistance: 600 ohms maximum for 4- 20 mA loop current
signal

Self-Test : Automatic self-test of sensor integrity
upon power ON.

Calibration : Non-Intrusive, via magnetic switches

Display : Alphanumeric LCD/OLED display with backlight.
Diagnostic status display & continuous readout of
gas concentration present. (ppm, %LEL or % V/V).

Alarm setting: Two set-points - User Selectable.

Relay Contacts : Three Potential free Relay contacts, 10 Amp
at 230VAC.

Communication: Rs-485 (MODBUS-RTU)/HART

Physical Dimensions: (Approx. Outline dimension including sensor
Adaptor & cable glands)

Width=145mm, Height=155mm, Depth=100mm.

Weight : 2.5 Kg (approximately)

Cable entries: M20 / ½" N.P.T

Warranty : Instrument - 1 year
Sensor - 1 year (on proportional basis)

Approval (Optional):

1.	ATEX	 II 2 G Ex db IIC T6 Gb (T _{amb} = -20°C to +40°C) Ex db IIC T5 Gb (T _{amb} = -20°C to +55°C)
2.	IECEX	Ex db IIC T6 Gb (T _{amb} = -20°C to +40°C) Ex db IIC T5 Gb (T _{amb} = -20°C to +55°C)

ENVIRONMENTAL SPECIFICATIONS:

Operating Temperature : 0 to 50C ± 5%

Humidity : Relative humidity:90% non-condensing

 **Note:** Extended exposure to extreme humidity conditions will degrade sensor performance.

MODBUS REGISTER MAP

Serial Settings

Baud rate	:	9600 bps
Parity	:	None
Data Bits	:	8
Stop Bit	:	1

ModBus Register No.	Parameter	Applicable Modbus Functions	Description	Values
1	rtc-date	03	current date	0 - 31 date
2	Rtc-month	03	current month	0 - 12 month
3	Rtc-year	03	current year	0 - 99 year
4	sensor mfg date	03	manufacturing date	0 - 31 date
5	sensor mfg month	03	manufacturing month	0 - 12 month
6	sensor mfg year	03	manufacturing year	0 -99 year
7	calibration date	03	calibration date	0 – 31 date
8	calibration month	03	calibration month	0 – 12 month
9	calibration year	03	calibration year	0 – 99 year
10	sensor rngl	03	sensor range low	0 – 9999
11	sensor rngh	03	sensor range high	0 – 9999
12	sensor tlv	03,06	sensor threshold level	0 – 9999
13	sensor stlv	03,06	sensor stlv	0 – 9999
14	Ambient Temperature	03	ambient	0 – 999
15	Decimal points	03	resolution	0 – 4
16	Calibration Gas value	03	span	20% to 80% of range high
17 – 24	sensor gas name	03	sensor gas name	sensor gas name
25 – 28	sensor gas unit	03	sensor gas unit	sensor gas unit
29	SS life	03	sensor Days	0 – 9999
30	no of calibrations	03	calibration attempts	0 – 9999 times calibration attempt.
31	Status coils	03	coil value	(0 – 9) bit status of coil.
				0 – zero calibration process
				1 – zero calibration pass
				2 – zero calibration fail
				3- RESERVERD
				4 – span calibration process
				5 – span calibration pass
				6 – span calibration fail

				7 – relay1 status
				8 – relay2 status
				9 – Gas drift
				10 – date fail
				11 -15 RESERVED
32	g1	03	Process Value	0 -9999 (value)
				0x7FFD – sensor not connect
				0x7FFF – sensor over
				0x7FFE – sensor drift

Notes:

**(Due to continuing development we reserve the right to
Change specifications without prior notice)**

Manufactured At

Uniphos Envirotronic Pvt. Ltd.

P. O. Nahuli, Tal. Umbergaon,
Dist. Valsad - 396 108, India
Mo. No. : +91-9909994042
+91-7574839945

Email Id:

info@uniphos-envirotronic.com

Marketing Office

Uniphos Envirotronic Pvt. Ltd.

Ready money Terrace
167 Dr. Annie Besant Road
Worli, Mumbai 400 018, INDIA
TEL: (+91 22) 2493 0681
FAX: (+91 22) 2493 8826
E-Mail: info@uniphos-envirotronic.com

After Sales Support: email-id: service@uniphos-envirotronic.com

Website: www.uniphos-envirotronic.com

Issue: 0

Rev:01

Date: 02.08.22